

DUAL LOW-VOLTAGE POWER AMPLIFIER

- SUPPLY VOLTAGE DOWN TO 1.8V
- LOWCROSSOVER DISTORTION
- LOW QUIESCENT CURRENT
- BRIDGE OR STEREO CONFIGURATION

DESCRIPTION

The TDA2822D is a monolithic integrated circuit in 8 lead (SO-8) package. It is intended for use as dual audio power amplifier in portable cassette players, radios and CD players

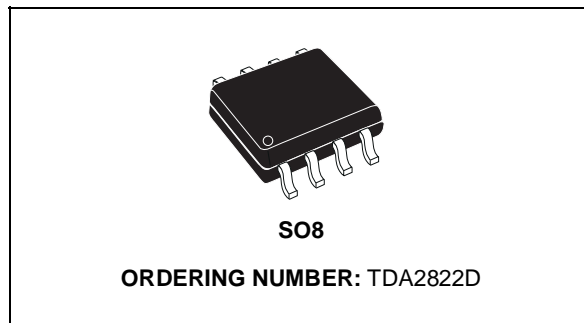

ABSOLUTE MAXIMUM RATINGS

Symbol	Parameter	Value	Unit
V_S	Supply Voltage	15	V
I_O	Peak Output	1	A
P_{tot}	Total Power Dissipation $T_{amb} = 50^\circ\text{C}$	0.5	W
T_{stg}, T_j	Storage and Junction Temperature	-40 to 150	$^\circ\text{C}$

APPLICATION CIRCUIT

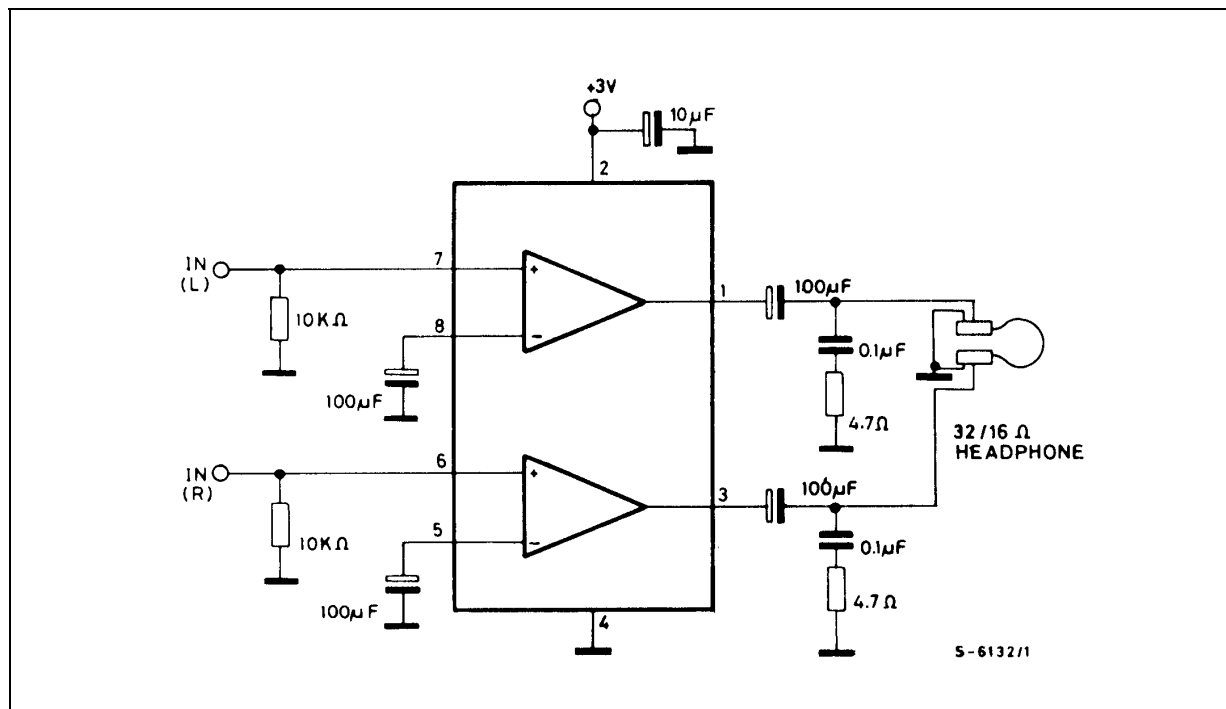

TDA2822D

PIN CONNECTION (Top view)

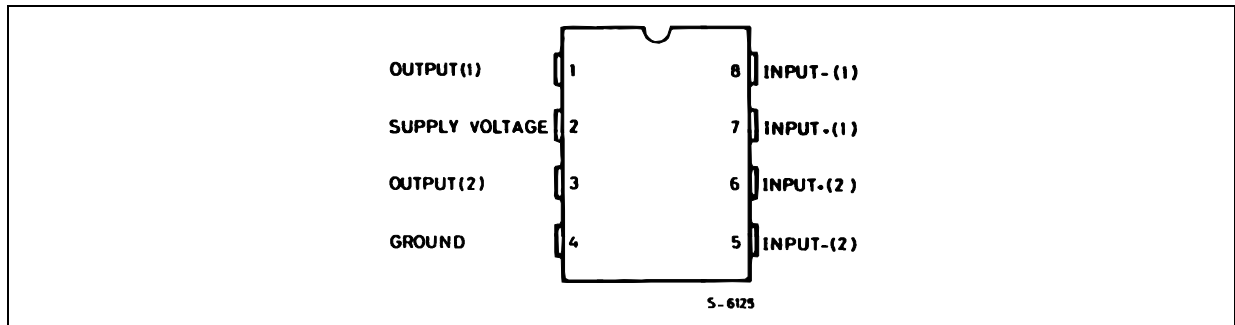

THERMAL DATA

Symbol	Description	Value	Unit
$R_{th\ j-amb}$	Thermal Resistance Junction-ambient	Max 200	°C/W

Figure 1: Stereo Application and Test Circuit

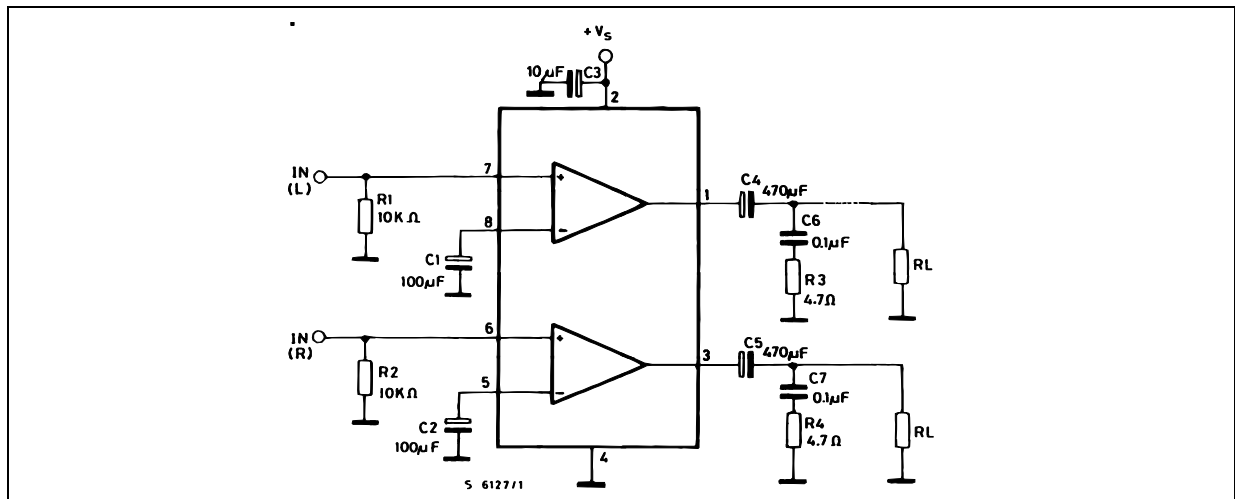
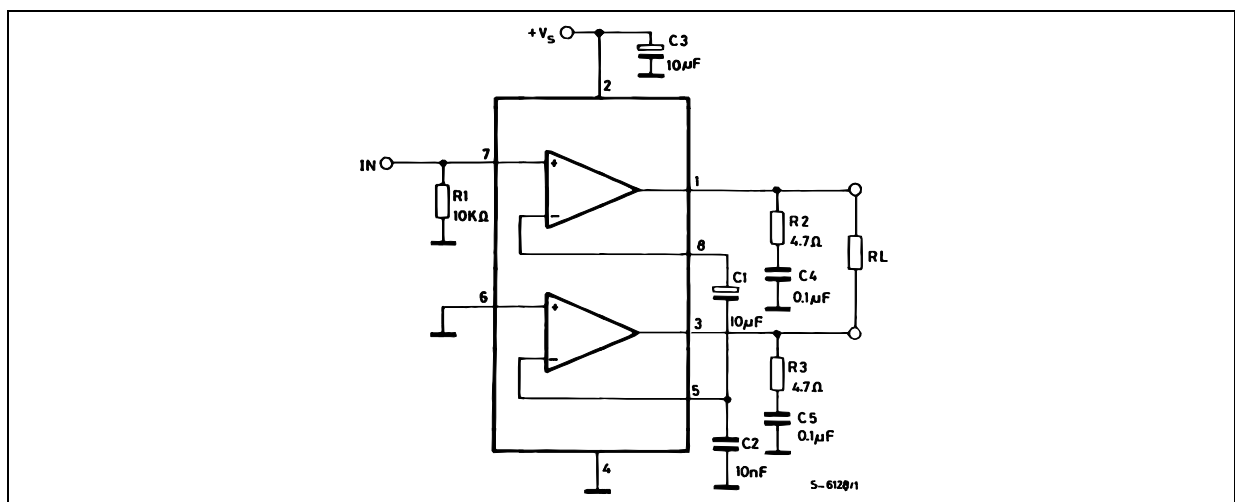

Figure 2: Bridge Application and Test Circuit



ELECTRICAL CHARACTERISTICS ($V_S = 6V$; $T_{amb} = 25^\circ C$, unless otherwise specified).

STEREO (Test circuit of fig. 1).

Symbol	Parameter	Test Condition	Min.	Typ.	Max.	Unit
V_S	Supply Voltage		1.8		15	V
I_d	Total Quiescent Drain Current				15	mA
V_O	Quiescent Output Voltage			2.7		V
		$V_S = 3V$		1.2		V
I_b	Input Bias Current			100		nA
P_O	Output Power (each channel) ($f = 1KHz$, $d = 10\%$)	$R_L = 32\Omega$ $V_S = 9V$ $V_S = 6V$ $V_S = 4.5V$ $V_S = 3V$ $V_S = 2V$		300 120 60 20 5		mW
		$R_L = 16\Omega$ $V_S = 6V$	170	220		mW
		$R_L = 8\Omega$ $V_S = 6V$	300	380		mW
		$R_L = 4\Omega$ $V_S = 4.5V$ $V_S = 3V$		320 110		mW mW
d	Distortion	$R_L = 32\Omega$ $P_O = 40mW$		0.2		%
		$R_L = 16\Omega$ $P_O = 75mW$		0.2		%
		$R_L = 8\Omega$ $P_O = 150mW$		0.2		%
G_V	Closed Loop Voltage Gain	$f = 1KHz$	36	39	41	dB
ΔG_V	Channel Balance				± 1	dB
R_i	Input Resistance	$f = 1KHz$	100			$K\Omega$
e_N	Total Input Noise	$R_S = 10k\Omega$ B = Curve A		2		μV
		$R_S = 10k\Omega$ B = 22Hz to 22KHz		2.5		μV
SVR	Supply Voltage Rejection	$f = 100Hz$ $C_1 = C_2 = 100\mu F$	24	30		dB
C_s	Channel Separation	$f = 1KHz$		50		dB

BRIDGE (Test circuit of fig.2)

V_S	Supply Voltage		1.8		15	V
I_d	Total Quiescent Drain Current	$R_L = \infty$			15	mA
V_{os}	Output Offset Voltage (between the outputs)	$R_L = 8\Omega$			± 80	mV
I_b	Input Bias Current			100		nA
P_O	Output Power ($f = 1KHz$, $d = 10\%$)	$R_L = 32\Omega$ $V_S = 9V$ $V_S = 6V$ $V_S = 4.5V$ $V_S = 3V$ $V_S = 2V$	320 50	1000 400 200 65 8		mW
		$R_L = 16\Omega$ $V_S = 6V$ $V_S = 3V$		800 120		mW mW
		$R_L = 8\Omega$ $V_S = 4.5V$ $V_S = 3V$		700 220		mW mW
		$R_L = 4\Omega$ $V_S = 3V$ $V_S = 2V$		350 80		mW mW
d	Distortion	$R_L = 8\Omega$ $P_O = 0.5W$ $f = 1KHz$		0.2		%
G_V	Closed Loop Voltage Gain	$f = 1KHz$		39		dB
R_i	Input Resistance	$f = 1KHz$	100			$K\Omega$
e_N	Total Input Noise	$R_S = 10k\Omega$ B = Curve A		2.5		μV
		$R_S = 10k\Omega$ B = 22Hz to 22KHz		3		μV
SVR	Supply Voltage Rejection	$f = 100Hz$		40		dB
B	Power Bandwidth (-3dB)	$R_L = 8\Omega$ $P_O = 1W$		120		KHz

Figure 3: Supply Voltage Rejection vs. Frequency

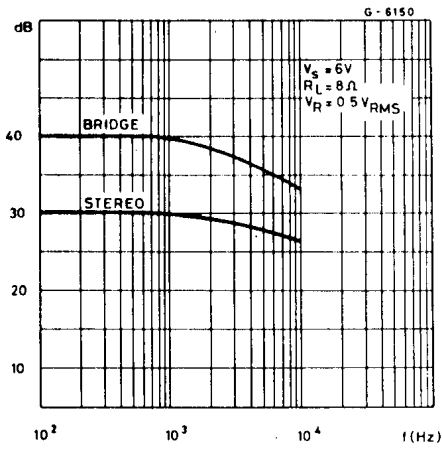

Figure 4: Output Power vs. Supply Voltage (THD = 10%, f = 1KHz Stereo)

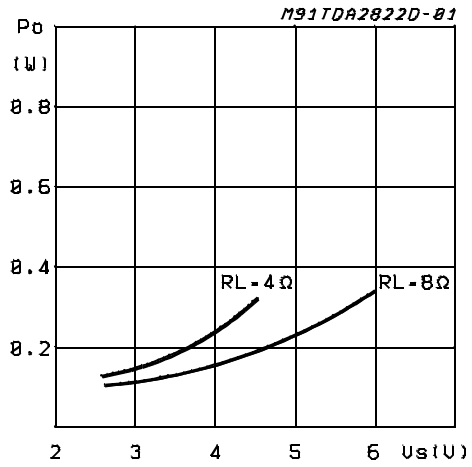

Figure 5: Total Power Dissipation vs. Output Power (Bridge)

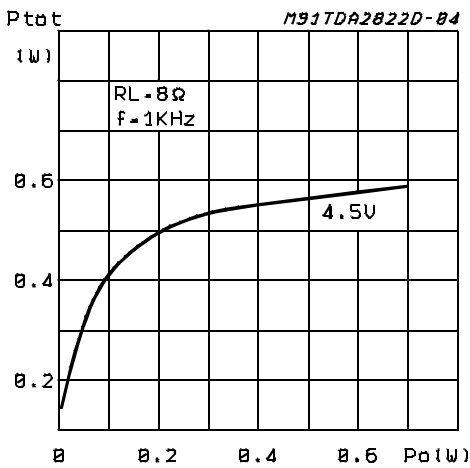
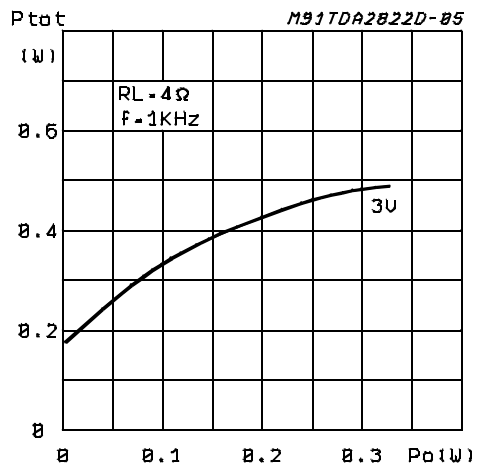
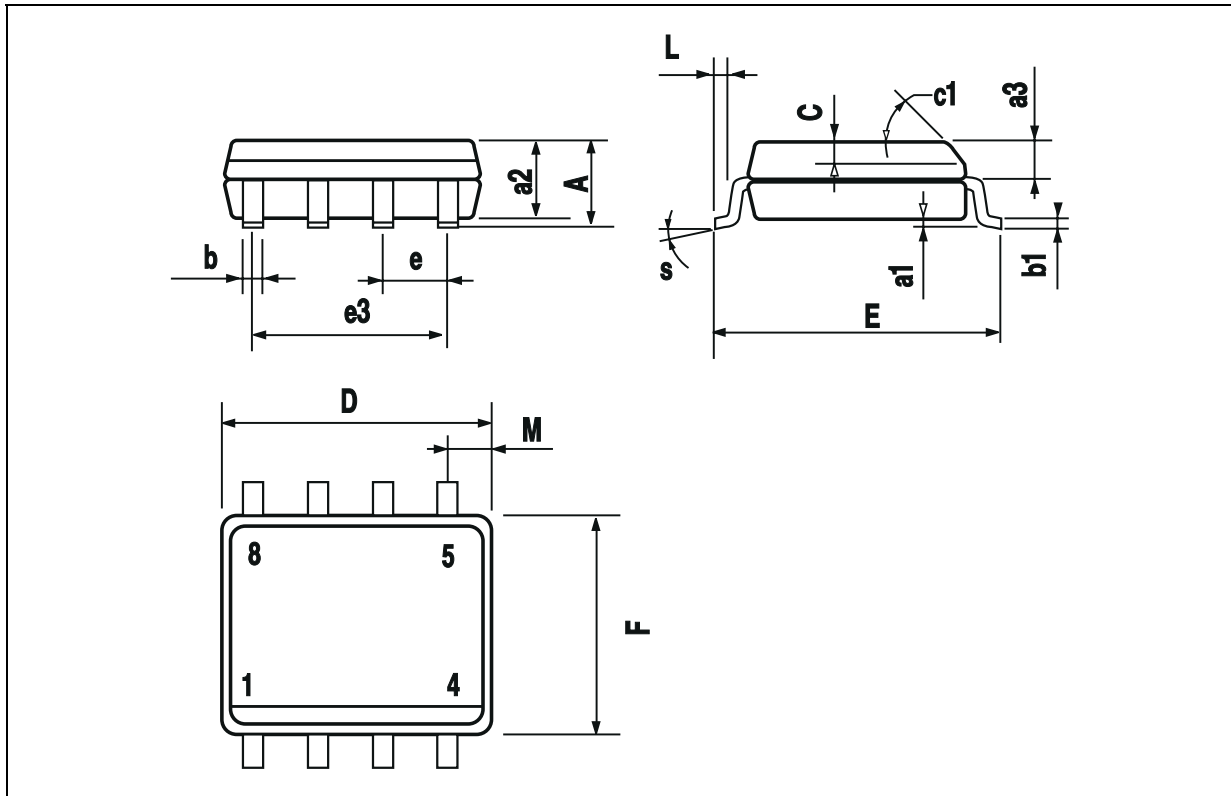

Figure 6: Total Power Dissipation vs. Output Power (Bridge)



SO8 PACKAGE MECHANICAL DATA

DIM.	mm			inch		
	MIN.	TYP.	MAX.	MIN.	TYP.	MAX.
A			1.75			0.069
a1	0.1		0.25	0.004		0.010
a2			1.65			0.065
a3	0.65		0.85	0.026		0.033
b	0.35		0.48	0.014		0.019
b1	0.19		0.25	0.007		0.010
C	0.25		0.5	0.010		0.020
c1	45° (typ.)					
D	4.8		5.0	0.189		0.197
E	5.8		6.2	0.228		0.244
e		1.27			0.050	
e3		3.81			0.150	
F	3.8		4.0	0.15		0.157
L	0.4		1.27	0.016		0.050
M			0.6			0.024
S	8° (max.)					



Information furnished is believed to be accurate and reliable. However, SGS-THOMSON Microelectronics assumes no responsibility for the consequences of use of such information nor for any infringement of patents or other rights of third parties which may result from its use. No license is granted by implication or otherwise under any patent or patent rights of SGS-THOMSON Microelectronics. Specifications mentioned in this publication are subject to change without notice. This publication supersedes and replaces all information previously supplied. SGS-THOMSON Microelectronics products are not authorized for use as critical components in life support devices or systems without express written approval of SGS-THOMSON Microelectronics.

© 1994 SGS-THOMSON Microelectronics - All Rights Reserved

SGS-THOMSON Microelectronics GROUP OF COMPANIES

Australia - Brazil - France - Germany - Hong Kong - Italy - Japan - Korea - Malaysia - Malta - Morocco - The Netherlands - Singapore - Spain - Sweden - Switzerland - Taiwan - Thailand - United Kingdom - U.S.A.

This datasheet has been download from:

www.datasheetcatalog.com

Datasheets for electronics components.